

11 July 2001

AGREEMENT

CONCERNING THE ADOPTION OF UNIFORM TECHNICAL PRESCRIPTIONS FOR WHEELED VEHICLES, EQUIPMENT AND PARTS WHICH CAN BE FITTED AND/OR BE USED ON WHEELED VEHICLES AND THE CONDITIONS FOR RECIPROCAL RECOGNITION OF APPROVALS GRANTED ON THE BASIS OF THESE PRESCRIPTIONS */

(Revision 2, including the amendments entered into force on 16 October 1995)

Addendum 89: Regulation No. 90

Revision 1

Incorporating all valid text up to:

01 series of amendments - Date of entry into force: 18 September 1994
Supplement 1 to the 01 series of amendments - Date of entry into force: 14 August 1995
Supplement 2 to the 01 series of amendments - Date of entry into force: 5 March 1997
Corrigendum 1 to Supplement 2 to the 01 series of amendments (Erratum)
Corrigendum 2 to Supplement 2 to the 01 series of amendments subject of Depository Notification
C.N.329.1998.TREATIES-80 dated 5 August 1998
Corrigendum 3 to Supplement 2 to the 01 series of amendments subject of Depository Notification
C.N.657.1999.TREATIES-1 dated 20 July 1999
Corrigendum 4 to Supplement 2 to the 01 series of amendments subject of Depository Notification
C.N.460.2000.TREATIES-1 dated 30 June 2000
Supplement 3 to the 01 series of amendments - Date of entry into force: 13 November 1999
Supplement 4 to the 01 series of amendments - Date of entry into force: 29 December 2000

UNIFORM PROVISIONS CONCERNING THE APPROVAL OF REPLACEMENT BRAKE LINING ASSEMBLIES AND DRUM BRAKE LININGS FOR POWER-DRIVEN VEHICLES AND THEIR TRAILERS



UNITED NATIONS

*/ Former title of the Agreement:

Agreement Concerning the Adoption of Uniform Conditions of Approval and Reciprocal Recognition of Approval for Motor Vehicle Equipment and Parts, done at Geneva on 20 March 1958.

GE.01-

Regulation No. 90

UNIFORM PROVISIONS CONCERNING THE APPROVAL OF
REPLACEMENT BRAKE LINING ASSEMBLIES AND DRUM BRAKE LININGS
FOR POWER-DRIVEN VEHICLES AND THEIR TRAILERS

CONTENTS

REGULATION	<u>Page</u>
1. Scope	5
2. Definitions	5
3. Application for approval	5
4. Approval	5
5. Specifications and tests	6
6. Packaging and marking	11
7. Modifications and extension of approval of the replacement brake lining assembly or the replacement drum brake lining	12
8. Conformity of production	12
9. Penalties for non-conformity of production	14
10. Production definitely discontinued	14
11. Names and addresses of technical services responsible for conducting approval tests, and of administrative departments	14
12. Transitional provisions	14

ANNEXES

- Annex 1 - Communication concerning the approval or extension or refusal or withdrawal of approval or production definitely discontinued of a replacement brake lining assembly or replacement drum brake lining pursuant to Regulation No. 90
- Annex 2 - Arrangements of the approval mark and approval data
- Annex 3 - Requirements for replacement brake lining assemblies for vehicles of categories M₁, M₂ and N₁
- Annex 4 - Requirements for replacement brake lining assemblies and drum brake linings for vehicles of categories M₃, N₂ and N₃
- Annex 5 - Requirements for replacement brake lining assemblies for vehicles of categories O₁ and O₂

CONTENTS (continued)

- Annex 6 - Requirements for replacement brake lining assemblies and drum
brake linings for vehicles of categories O₃ and O₄
- Annex 7 - Requirements for replacement brake lining assemblies for vehicles
of category L
- Annex 8 - Determination of friction behaviour by machine testing

* * *

1. SCOPE

- 1.1. This Regulation applies to replacement service brake lining assemblies intended for use in friction brakes forming part of the braking system of power-driven vehicles and their trailers authorized for use on public roads.
- 1.2. Replacement brake lining assemblies may be approved for fitment and use on power-driven vehicles and trailers having type approval in accordance with Regulation No. 13 or Regulation No. 78. Replacement drum brake linings designed to be riveted to a brake shoe may be approved for fitment and use on power-driven vehicles and trailers having type approval in accordance with Regulation No. 13 and classified in categories M₃, N₂, N₃, O₃ and O₄. 1/

2. DEFINITIONS

For the purposes of this Regulation;

- 2.1. "Braking system" has the meaning assigned in Regulation No. 13, paragraph 2.3.;
- 2.2. "Friction brake" means the part of a braking system in which the forces opposing the movement of a vehicle are developed by friction between a brake lining and a wheel disc or drum moving relatively to each other;
- 2.3. "Brake lining assembly" means a component of a friction brake which is pressed against a drum or disc, respectively, to produce the friction force;
- 2.3.1. "Shoe assembly" means a brake lining assembly of a drum brake;
- 2.3.1.1. "Shoe" means a component of a shoe assembly which carries the brake lining;
- 2.3.2. "Pad assembly" means a brake lining assembly of a disc brake;
- 2.3.2.1. "Backplate" means a component of a pad assembly which carries the brake lining;
- 2.3.3. "Brake lining" means the friction material component with the shape and final dimension to be fixed on to the shoe or backplate;
- 2.3.4. "Drum brake lining" means a brake lining for a drum brake.
- 2.3.5. "Friction material" means the product of a specified mixture of materials and processes which together determine the characteristics of a brake lining;
- 2.4. "Brake lining type" means a category of brake linings which do not differ in friction material characteristics;

1/ In this Regulation, references to Regulation No. 13 shall be deemed to refer also to any other international rule that applies the same technical requirements as Regulation No. 13. References to specific sections of the Regulation shall be interpreted accordingly.

- 2.5. "Brake lining assembly type" means wheel sets of brake lining assemblies which do not differ in brake lining type, dimension or functional characteristics;
- 2.6. "Drum brake lining type" means wheel sets of brake lining components which after fitment to the shoes do not differ in brake lining type, dimensions or functional characteristics.
- 2.7. "Original brake lining" means a brake lining type referenced in the vehicle type approval documentation, Regulation No. 13, annex 2, paragraph 8.1. 2/ or Regulation No. 78, annex 1, paragraph 5.4.;
- 2.8. "Original brake lining assembly" means a brake lining assembly conforming to the data attached to a vehicle type approval documentation;
- 2.9. "Replacement brake lining assembly" means a brake lining assembly of a type approved under this Regulation as a suitable service replacement for an original brake lining assembly;
- 2.10. "Original drum brake lining" means a drum brake lining conforming to the data attached to a vehicle type approval documentation.
- 2.11. "Replacement drum brake lining" means a drum brake lining of a type approved under this Regulation as a suitable service replacement when fitted to a shoe for an original drum brake lining.
- 2.12. "Manufacturer" means the organization which can assume technical responsibility for the brake lining assemblies or drum brake linings and can demonstrate that it possesses the necessary means to achieve conformity of production.
3. APPLICATION FOR APPROVAL
- 3.1. An application for approval of a replacement brake lining assembly type or a replacement drum brake lining type for (a) specific vehicle type(s) shall be submitted by the manufacturer of the replacement lining assembly/replacement drum brake lining or his duly accredited representative.
- 3.2. An application may be submitted by the holder of (a) vehicle type approval(s) to Regulation No. 13 or Regulation No. 78 in respect of replacement brake lining assemblies or replacement drum brake linings conforming to the type recorded in the vehicle type approval(s) documentation.
- 3.3. An application for approval shall be accompanied, in triplicate, by a description of the replacement brake lining assembly or replacement drum brake lining with regard to the items specified in annex 1 to this Regulation, and by the following particulars:

2/ If such brake linings are not available on the market, alternatively, brake linings listed under paragraph 8.2. may be used.

- 3.3.1. diagrams showing functional dimensions of the replacement brake lining assembly or replacement drum brake lining;
- 3.3.2. an indication of the positions of the replacement brake lining assembly or replacement drum brake lining on the vehicles for which approval to fit is sought.
- 3.4. Brake lining assemblies or drum brake linings of the type for which approval is sought shall be made available in sufficient quantity to perform the approval tests.
- 3.5. The applicant shall agree with and make available to the technical service responsible for conducting approval tests the suitable representative vehicle(s) and/or brake(s).
- 3.6. The competent authority shall verify the existence of satisfactory arrangements for ensuring effective control of the conformity of production before type approval is granted.
 - 3.6.1. The applicant shall submit values for friction behaviour in accordance with annex 8, paragraph 2.4.1. or 3.4.1. respectively of this Regulation.
4. APPROVAL
 - 4.1. If the brake lining assemblies or drum brake linings submitted for approval pursuant to this Regulation meet the requirements of paragraph 5. below, approval of the replacement brake lining assembly type or replacement drum brake lining type shall be granted.
 - 4.1.1. In the case of replacement brake lining assemblies for vehicles of category L with a combined braking system in the meaning of paragraph 2.9. of Regulation No. 78, the approval must be restricted to the brake lining assembly combination(s) on the axles of the vehicle having been tested according to annex 7 of this Regulation.
 - 4.2. To each replacement brake lining assembly type or drum brake lining type approved there shall be assigned an approval number comprising three groups of digits:
 - 4.2.1. The first two digits (at present 01 for the Regulation in its 01 series of amendments) shall indicate the series of amendments incorporating the most recent major technical amendments made to the Regulation at the time of issue of the approval.
 - 4.2.2. The following three digits shall indicate the brake lining type.
 - 4.2.3. A suffix of three digits shall indicate the shoe or backplate or specific dimension in the case of drum brake linings.
 - 4.3. The same Contracting Party may not assign the same number to another brake lining assembly type or drum brake lining type. The same type approval number may cover the use of that brake lining assembly type or drum brake lining type on a number of differing vehicle types.

- 4.4. Notice of approval or of extension or refusal of approval or withdrawal of approval or production definitely discontinued of a brake lining assembly type or drum brake lining type pursuant to this Regulation shall be communicated to the Parties to the 1958 Agreement which apply this Regulation by means of a form conforming to the model in annex 1 to this Regulation.
- 4.5. There shall be affixed, conspicuously and in a readily accessible place, to every brake lining assembly or drum brake lining of a type approved under this Regulation, an international approval mark consisting of:
- 4.5.1. a circle surrounding the letter "E" followed by the distinguishing number of the country which has granted approval; 3/
- 4.5.2. the number of this Regulation, followed by the letter "R", a dash and the approval number to the right of the circle prescribed in paragraph 4.5.1.
- 4.6. The approval mark referred to in paragraph 4.5. above shall be clearly legible and be indelible.
- 4.7. Annex 2 to this Regulation gives examples of arrangements of the approval mark and approval data referred to above and in paragraph 6.5. below.
5. SPECIFICATIONS AND TESTS
- 5.1. General
- A replacement brake lining assembly or a replacement drum brake lining shall be so designed and constructed that, when substituted for the assembly or lining originally fitted to a vehicle, the braking efficiency of that vehicle accords with that of the approved vehicle type.

3/ 1 for Germany, 2 for France, 3 for Italy, 4 for the Netherlands, 5 for Sweden, 6 for Belgium, 7 for Hungary, 8 for the Czech Republic, 9 for Spain, 10 for Yugoslavia, 11 for the United Kingdom, 12 for Austria, 13 for Luxembourg, 14 for Switzerland, 15 (vacant), 16 for Norway, 17 for Finland, 18 for Denmark, 19 for Romania, 20 for Poland, 21 for Portugal, 22 for the Russian Federation, 23 for Greece, 24 for Ireland, 25 for Croatia, 26 for Slovenia, 27 for Slovakia, 28 for Belarus, 29 for Estonia, 30 (vacant), 31 for Bosnia and Herzegovina, 32 for Latvia, 33 (vacant), 34 for Bulgaria, 35-36 (vacant), 37 for Turkey, 38-39 (vacant), 40 for The former Yugoslav Republic of Macedonia, 41 (vacant), 42 for the European Community (Approvals are granted by its Member States using their respective ECE symbol), 43 for Japan, 44 (vacant), 45 for Australia, 46 for Ukraine and 47 for South Africa. Subsequent numbers shall be assigned to other countries in the chronological order in which they ratify or accede to the Agreement Concerning the Adoption of Uniform Technical Prescriptions for Wheeled Vehicles, Equipment and Parts which can be Fitted and/or be Used on Wheeled Vehicles and the Conditions for Reciprocal Recognition of Approvals Granted on the Basis of these Prescriptions, and the numbers thus assigned shall be communicated by the Secretary-General of the United Nations to the Contracting Parties to the Agreement.

Specifically:

- (a) a vehicle equipped with replacement brake lining assemblies or replacement drum brake linings shall satisfy the relevant braking prescriptions of Regulation No. 13 including the 09 series of amendments or Regulation No. 78 including the 01 series of amendments;
- (b) a replacement brake lining assembly or a replacement drum brake lining shall display performance characteristics similar to that of the original brake lining assembly or original drum brake lining it is intended to replace;
- (c) a replacement lining assembly or a replacement drum brake lining must possess adequate mechanical characteristics.
- (d) brake linings shall not contain asbestos.

5.1.1. Replacement brake lining assemblies or replacement drum brake linings conforming to the type specified in vehicle type approval documentation to Regulation No. 13 or Regulation No. 78, are deemed to satisfy the requirements of paragraph 5. of this Regulation.

5.2. Performance requirements

5.2.1. Replacement brake lining assemblies for vehicles of categories M₁, M₂ and N₁

Replacement brake lining assemblies shall be tested according to the prescriptions of annex 3 and must satisfy the requirements stated in this annex. For speed sensitivity and cold performance equivalence one of the two methods described in annex 3 shall be used.

5.2.2. Replacement brake lining assemblies and replacement drum brake linings for vehicles of categories M₃, N₂ and N₃

Replacement brake lining assemblies and replacement drum brake linings shall be tested according to the prescriptions of annex 4, using one of the two methods described in paragraph 1 (vehicle test) or in paragraph 2 (inertia dynamometer test) and shall satisfy the requirements stated in this annex.

5.2.3. Replacement brake lining assemblies for vehicles of categories O₁ and O₂

Replacement brake lining assemblies shall be tested according to the prescriptions of annex 5 and shall satisfy the requirements stated in this annex.

5.2.4. Replacement brake lining assemblies and replacement drum brake linings for vehicles of categories O₃ and O₄

Replacement brake lining assemblies and replacement drum brake linings shall be tested according to the prescriptions of annex 6 and shall satisfy the requirements stated in this annex. For the tests one of the three methods described in paragraph 3 of appendix 2 to annex 11 of Regulation No. 13 shall be used.

5.2.5. Replacement brake lining assemblies for vehicles of category L

Replacement brake lining assemblies shall be tested according to the prescriptions of annex 7 and shall satisfy the requirements stated in this annex.

5.3. Mechanical characteristics

5.3.1. Replacement brake lining assemblies for vehicles of categories M₁, M₂, N₁, O₁, O₂, and L

5.3.1.1. Replacement brake lining assemblies of the type for which approval is requested shall be tested for shear strength according to Standard ISO 6312:1981.

The minimum acceptable shear strength is 250 N/cm² for pad assemblies and 100 N/cm² for shoe assemblies.

5.3.1.2. Replacement brake lining assemblies of the type for which approval is requested shall be tested for compressibility according to Standard ISO 6310:1981.

The compressibility values shall not exceed 2 per cent at ambient temperature and 5 per cent at 400 EC for pad assemblies and 2 per cent at ambient temperature and 4 per cent at 200 EC for shoe assemblies.

5.3.2. Replacement brake lining assemblies and replacement drum brake linings for vehicles of categories M₃, N₂, N₃, O₃, and O₄

5.3.2.1. Shear strength

This test applies only to disc brake pad assemblies.

Replacement brake lining assemblies of the type for which approval is requested shall be tested for shear strength according to Standard ISO 6312:1981. Brake lining assemblies may be divided into two or three parts to match the test machine's capability.

The minimum acceptable shear strength is 250 N/cm².

5.3.2.2. Compressibility

Replacement brake lining assemblies and replacement drum brake linings of the type for which approval is requested shall be tested for compressibility according to Standard ISO 6310:1981. Flat specimens according to sample type I may be used.

The compressibility values shall not exceed 2 per cent at ambient temperature and 5 per cent at 400 EC for pad assemblies and 2 per cent at ambient temperature and 4 per cent at 200 EC for shoe assemblies and drum brake linings.

5.3.2.3. Material hardness 4/

This requirement applies to drum brake lining assemblies and drum brake linings.

Replacement brake lining assemblies or replacement drum brake linings of the type for which approval is requested shall be tested for hardness according to Standard ISO 2039-2:1987.

The hardness figure for the friction material at the rubbing surface shall be the mean value out of five sample linings from different production batches (if available) by taking five measurements at different places of each brake lining.

6. PACKAGING AND MARKING

6.1. Replacement brake lining assemblies or replacement drum brake linings conforming to a type approved in accordance with this Regulation shall be marketed in axle sets.

6.2. Each axle set shall be contained in a sealed package constructed to show previous opening.

6.2.1. In the case of replacement drum brake linings rivets of suitable size and material shall be provided together with the brake linings.

6.3. Each package shall display the following information:

6.3.1. the quantity of replacement brake lining assemblies or replacement drum brake linings in the package;

6.3.2. manufacturer's name or trade mark;

6.3.3. make and type of replacement brake lining assemblies or replacement drum brake linings;

6.3.4. the vehicles/axles/brakes for which the contents are approved;

6.3.5. the approval mark.

6.4. Each package shall contain fitting instructions in an official ECE language, supplemented by the corresponding text in the language of the country where it is sold:

6.4.1. with particular reference to auxiliary parts;

6.4.2. stating that replacement brake lining assemblies or replacement drum brake linings should be replaced in axle sets;

6.4.3. with, in the case of replacement drum brake linings, a general statement calling attention to the following points:

the integrity of the shoe platform, abutment and pivot;

4/ This test is included for conformity of production purposes. Minimum values and the tolerances to be agreed with the Technical Service.

freedom of the shoe from distortion, deformation and corrosion;
the type and size of rivet to be used;
the required riveting tools and forces.

6.4.4. with, additionally, in the case of combined braking systems in the meaning of paragraph 2.9. of Regulation No. 78 giving the approved brake lining assembly combination(s).

6.5. Each replacement brake lining assembly or replacement drum brake lining shall display permanently one set of approval data:

6.5.1. the approval mark;

6.5.2. the date of manufacture, at least month and year;

6.5.3. make and type of brake lining.

7. MODIFICATIONS AND EXTENSION OF APPROVAL OF THE REPLACEMENT BRAKE LINING ASSEMBLY OR THE REPLACEMENT DRUM BRAKE LINING

7.1. Every modification of the replacement brake lining assembly type or replacement drum brake lining type shall be notified to the administrative department which granted the type approval. The department may then either:

7.1.1. consider that the modifications made are unlikely to have appreciable adverse effects and that in any event the brake lining assembly or drum brake lining still complies with the requirements; or

7.1.2. require a further test report from the technical service responsible for conducting the tests.

7.2. Confirmation or refusal of approval, specifying the alterations, shall be notified by the procedure specified in paragraph 4.4. above to the Parties to the 1958 Agreement applying this Regulation.

7.3. The competent authority issuing the extension of approval shall assign a series number for such an extension and inform thereof the other Parties to the 1958 Agreement applying this Regulation by means of a communication form conforming to the model in annex 1 to this Regulation.

8. CONFORMITY OF PRODUCTION

8.1. Replacement brake lining assemblies or replacement drum brake linings approved to this Regulation shall be so manufactured as to conform to the type approved.

8.2. Original brake lining assemblies or original drum brake linings being the subject of an application under paragraph 3.2. are deemed to satisfy the requirements of paragraph 8.

8.3. To verify that the requirements of paragraph 8.1. are met, suitable controls of the production shall be applied. These shall encompass the control of raw materials and components used.

- 8.4. The holder of an approval shall in particular:
- 8.4.1. ensure that for each replacement brake lining assembly type or replacement drum brake lining type at least the relevant tests prescribed in paragraph 5.3. and a friction behaviour test as prescribed in annex 8 to this Regulation are carried out on a statistically controlled and random basis in accordance with a regular quality assurance procedure;
 - 8.4.2. ensure existence of procedures for the effective control of the quality of products;
 - 8.4.3. have access to the control equipment necessary for checking the conformity of each approved type;
 - 8.4.4. analyse the results of each type of test in order to verify and ensure the consistency of the product characteristics, making allowance for variation of an industrial production;
 - 8.4.5. ensure that data of test results are recorded and that annexed documents remain available for a period to be determined in agreement with the administrative service;
 - 8.4.6. ensure that any samples or test pieces giving evidence of non-conformity with the type of test considered shall give rise to another sampling and another test. All the necessary steps shall be taken to re-establish the conformity of the corresponding production.
- 8.5. The competent authority which has granted type-approval may at any time verify the conformity control methods applicable to each production unit.
- 8.5.1. In every inspection, the test books and production survey records shall be presented to the visiting inspector.
 - 8.5.2. The inspector may take samples at random to be tested in the manufacturer's laboratory. The minimum number of samples may be determined according to the results of the manufacturer's own verification.
 - 8.5.3. When the quality level appears unsatisfactory or when it seems necessary to verify the validity of the tests carried out in application of paragraph 8.5.2. the inspector shall select samples to be sent to the technical service which has conducted the type approval tests.
 - 8.5.4. The competent authority may carry out any tests prescribed in this Regulation.
 - 8.5.5. The normal frequency of inspections authorized by the competent authority shall be one per year. In the case where negative results are recorded during one of these visits, the competent authority shall ensure that all necessary steps are taken to re-establish the conformity of production as rapidly as possible.

9. PENALTIES FOR NON-CONFORMITY OF PRODUCTION

9.1. The approval granted in respect of a replacement brake lining assembly type or drum brake lining type pursuant to this Regulation may be withdrawn if the requirements laid down in paragraph 8.1. above are not complied with,

9.2. If a Contracting Party to the Agreement applying this Regulation withdraws an approval it has previously granted, it shall forthwith so notify the other Contracting Parties applying this Regulation, by means of a communication form conforming to the model in annex 1 to this Regulation.

10. PRODUCTION DEFINITELY DISCONTINUED

If the holder of the approval completely ceases to manufacture a replacement brake lining assembly type or drum brake lining type approved in accordance with this Regulation, he shall so inform the authority which granted the approval. Upon receiving the relevant communication that authority shall inform thereof the other Parties to the 1958 Agreement applying this Regulation by means of a communication form conforming to the model in annex 1 to this Regulation.

11. NAMES AND ADDRESSES OF TECHNICAL SERVICES RESPONSIBLE FOR CONDUCTING APPROVAL TESTS, AND OF ADMINISTRATIVE DEPARTMENTS

The Contracting Parties to the 1958 Agreement which apply this Regulation shall communicate to the United Nations secretariat the names and addresses of the technical services responsible for conducting approval tests and of the administrative departments which grant approval and to which forms certifying approval or extension or refusal or withdrawal of approval, or production definitely discontinued, issued in other countries, are to be sent.

12. TRANSITIONAL PROVISIONS

12.1. No Contracting Party shall refuse to grant approvals under this Regulation as amended by the 01 series of amendments.

12.2. As from 1 January 1995, Contracting Parties applying this Regulation shall grant approvals only if the replacement brake lining assembly or the replacement drum brake lining approved meets the requirements of this Regulation as amended by the 01 series of amendments.

12.3. Contracting Parties applying this Regulation shall continue to allow fitting or use on a vehicle in use of a replacement brake lining assembly approved to this Regulation in its original, unamended form.

Annex 1

COMMUNICATION

(maximum format: A4 (210 x 297 mm))



issued by: Name of administration:
.....
.....
.....

concerning: 2/ APPROVAL GRANTED
APPROVAL EXTENDED
APPROVAL REFUSED
APPROVAL WITHDRAWN
PRODUCTION DEFINITELY DISCONTINUED

of a replacement brake lining assembly or replacement drum brake lining
pursuant to Regulation No. 90

Approval No. Extension No.

1. Applicant's name and address
2. Manufacturer's name and address
3. Make and type of brake lining assembly/drum brake lining 2/
.
4. Make and type of brake lining
5. Vehicles/axles/brakes for which the brake lining assembly type/drum
brake lining type qualifies as original brake lining assembly/original
drum brake lining:
.
6. Vehicles/axles/brakes for which the brake lining assembly type/drum
brake lining type qualifies as replacement brake lining
assembly/replacement drum brake lining:
.
- 6.1. additionally in the case of combined braking systems in the meaning of
paragraph 2.9. of Regulation No. 78, approved brake lining assembly
combination(s):
7. Submitted for approval on
8. Technical service responsible for approval tests
- 8.1. Date of test report
- 8.2. Number of test report

- 9. Approval granted/extended/refused/withdrawn 2/
- 10. Place
- 11. Date
- 12. Signature
- 13. Annexed to this communication is a list of documents in the approval file deposited at the administrative services having delivered the approval and which can be obtained upon request.



1/ Distinguishing number of the country which has granted/extended/refused/withdrawn approval (see approval provisions in the Regulation).

2/ Strike out what does not apply.

Annex 2

ARRANGEMENTS OF THE APPROVAL MARK AND APPROVAL DATA

(See paragraph 4.7. of this Regulation)

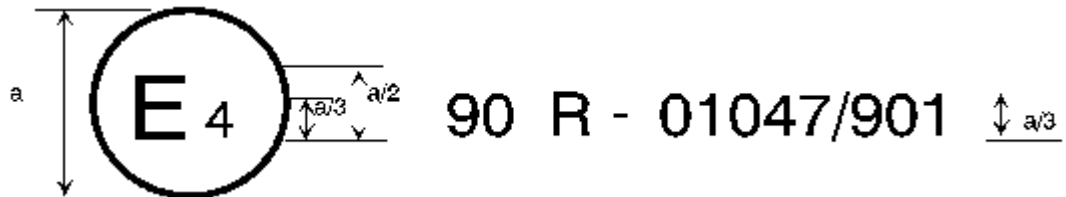

a = 8 mm min.

The above approval mark shows that the item concerned has been approved in the Netherlands (E4) pursuant to Regulation No. 90. In this illustration the first two digits of the approval number indicate that Regulation No. 90 already included the 01 series of amendments when the approval number was granted; the following three digits are those allocated by the approval authority to the brake lining type, and the suffix digits are those allocated by the approval authority to the shoe or backplate. All eight digits together comprise the approval number for that replacement brake lining assembly type.

Example of pad assembly marking

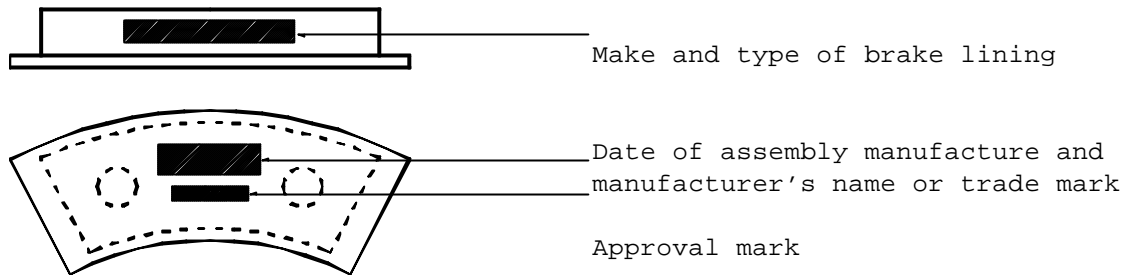

Example of shoe assembly marking

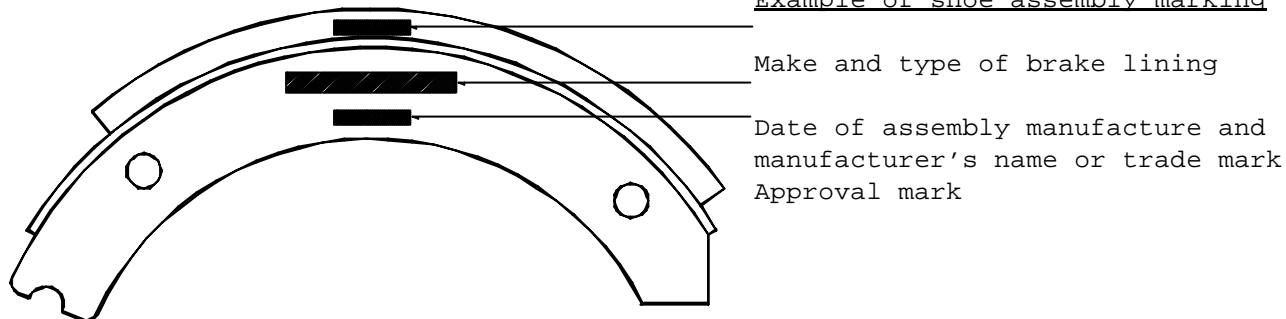

Example of drum brake lining marking

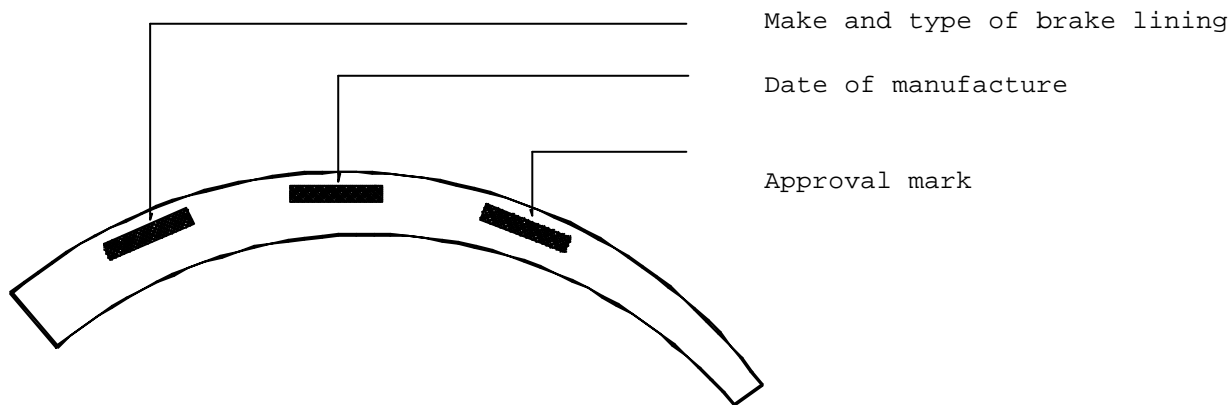

Note: Positions of markings and mutual positions of markings shown in the examples are not mandatory.

Annex 3

REQUIREMENTS FOR REPLACEMENT BRAKE LINING ASSEMBLIES FOR VEHICLES
OF CATEGORIES M₁, M₂ AND N₁

1. Conformance with Regulation No. 13

Compliance with the requirements of Regulation No. 13 shall be demonstrated in a vehicle test.

1.1. Test Vehicle

A vehicle which is representative of the type(s) for which the replacement brake lining assembly approval is required shall be equipped with the replacement brake lining assemblies of the type for which approval is requested and instrumented for brake testing as required by Regulation No. 13.

Brake linings submitted for test shall be fitted to the relevant brakes and, until a fixed burnishing procedure is established, shall be burnished to the manufacturer's instructions in agreement with the technical service.

1.2. The braking system of the vehicle shall be tested according to the requirements for the vehicle category in question (M₁, M₂ or N₁) in Regulation No. 13, annex 4, paragraphs 1. and 2. The applicable requirements or tests are:

1.2.1. Service braking system

1.2.1.1. Type-0 test with engine disconnected, vehicle laden

1.2.1.2. Type-0 test with engine connected, vehicle unladen and laden, according to Regulation No. 13, annex 4, paragraphs 1.4.3.1. (stability test) and 1.4.3.2. (only the test with initial speed $v = 0.8 v_{\max}$)

1.2.1.3. Type-I test

1.2.2. Secondary braking system

1.2.2.1. Type-0 test with engine disconnected, vehicle laden (this test may be omitted in cases where it is obvious that the requirements are met, e.g. diagonal split braking system)

1.2.3. Parking braking system

(Only applicable if the brakes for which lining approval is sought are used for parking).

1.2.3.1. Downhill test at 18 per cent gradient, vehicle laden

1.3. The vehicle must satisfy all the relevant requirements stated in Regulation No. 13, annex 4, paragraph 2. for that category of vehicles.

2. Additional requirements

Compliance with the additional requirements shall be demonstrated by using one of the two following methods:

2.1. Vehicle test (split axle test)

For this test the vehicle shall be fully laden and all brake applications made with engine disconnected, on a level road.

The vehicle service brake control system shall be equipped with a means of isolating front and rear axle brakes so that either may be used independently of the other.

Where brake lining assembly approval is required for front axle brakes the rear axle brakes shall remain inoperative throughout the test.

Where brake lining assembly approval is required for rear axle brakes the front axle brakes shall remain inoperative throughout the test.

2.1.1. Cold performance equivalence test

A comparison of the cold performance of the replacement brake lining assembly and the original brake lining assembly shall be made by comparing the results of testing to the following method.

2.1.1.1. Make a minimum of six brake applications at spaced increments of pedal effort or line pressure up to wheel lock or, alternatively, up to a mean fully developed deceleration of 6 m/s^2 or up to the allowed maximum pedal force for the category of vehicle in question from an initial speed as given in the table below:

Vehicle category	Test speed in km/h	
	front axle	rear axle
M ₁	70	45
M ₂	50	40
N ₁	65	50

The initial brake temperature at the start of each application shall be # 100EC.

2.1.1.2. Note and plot pedal force or line pressure and mean fully developed deceleration for each application, and determine the pedal force or line pressure required to achieve (if possible) a mean fully developed deceleration of 5 m/s^2 for front axle brakes and 3 m/s^2 for rear axle brakes. If these values cannot be achieved with the maximum allowed pedal force determine alternatively the pedal force or line pressure required to achieve maximum deceleration.

2.1.1.3. The replacement brake lining assembly shall be considered to show similar performance characteristics to the original brake lining assembly if the achieved mean fully developed decelerations at the same control force or line pressure in the upper two thirds of the

generated curve are within 15 per cent of those obtained with the original brake lining assembly.

2.1.2. Speed sensitivity test

2.1.2.1. Using the pedal force derived from paragraph 2.1.1.2. of this annex and with initial brake temperature # 100EC, make three brake applications from each of the following speeds:

Front axle 65, 100 km/h and 135 km/h where v_{max} exceeds 150 km/h.

Rear axle 45, 65 km/h and 90 km/h where v_{max} exceeds 150 km/h.

2.1.2.2. Average the results for each group of three applications and plot speed against corresponding mean fully developed deceleration.

2.1.2.3. Mean fully developed decelerations recorded for the higher speeds shall lie within 15 per cent of that recorded for the lowest speed.

2.2. Inertia dynamometer test

2.2.1. Test equipment

For the tests an inertia dynamometer shall be equipped with the vehicle brake in question. The dynamometer shall be instrumented for continuous recording of rotational speed, brake torque, pressure in the brake line, number of rotations after brake application, braking time and brake rotor temperature.

2.2.2. Test conditions

2.2.2.1. The rotational mass of the dynamometer shall correspond to half the axle portion of the maximum vehicle mass as listed in the table below and to the rolling radius of the largest tyre that is authorized for that vehicle type(s).

Vehicle category	Axle portion of maximum vehicle mass	
	front	rear
M ₁	0.77	0.32
M ₂	0.69	0.44
N ₁	0.66	0.39

2.2.2.2. The initial dynamometer rotational speed shall correspond to the linear vehicle speed as stated in paragraphs 2.2.3. and 2.2.4. of this annex and shall be based on the dynamic rolling radius of the tyre.

2.2.2.3. Brake linings submitted for test shall be fitted to the relevant brakes and, until a fixed burnishing procedure is established, shall be burnished to the manufacturer's instructions in agreement with the technical service.

- 2.2.2.4. If cooling air is used, the speed of the airflow at the brake shall be:

$$v_{\text{air}} = 0.33v$$

where:

v = vehicle test speed at initiation of braking.

- 2.2.3. Cold performance equivalence test

A comparison of the cold performance of the replacement brake lining assembly and the original brake lining assembly shall be made by comparing the results of testing to the following method.

- 2.2.3.1. From the initial speed of 80 km/h for M_1 and N_1 and 60 km/h for M_2 and with brake temperature # 100EC at the start of each application make a minimum of six brake applications at spaced intervals of line pressure up to a mean fully developed deceleration of 6 m/s².
- 2.2.3.2. Note and plot line pressure and mean fully developed deceleration for each application, and determine line pressure required to achieve 5 m/s².
- 2.2.3.3. The replacement brake lining assembly shall be considered to show similar performance characteristics to the original brake lining assembly if the achieved mean fully developed decelerations at the same control force or line pressure in the upper two thirds of the generated curve are within 15 per cent of those obtained with the original brake lining assembly.
- 2.2.4. Speed sensitivity test
- 2.2.4.1. Using the line pressure derived from paragraph 2.2.3.2. and with initial brake temperature # 100EC make three brake applications from rotational speeds corresponding to vehicle linear speeds of:
75, 120 km/h and 160 km/h where v_{max} exceeds 150 km/h
- 2.2.4.2. Average the results for each group of three applications and plot speed against corresponding mean fully developed deceleration.
- 2.2.4.3. Mean fully developed decelerations recorded for the higher speeds shall lie within 15 per cent of that recorded for the lowest speed.
-

Annex 4

REQUIREMENTS FOR REPLACEMENT BRAKE LINING ASSEMBLIES AND DRUM BRAKE LININGS
FOR VEHICLES OF CATEGORIES M₃, N₂ AND N₃

1. Vehicle test

1.1. Test vehicle

A vehicle which is representative of the type(s) for which the replacement brake lining assembly approval or drum brake lining approval is required shall be equipped with brake lining assemblies or drum brake linings of the type for which approval is sought and instrumented for brake testing as required by Regulation No. 13.

Brake linings submitted for test shall be fitted to the relevant brakes and, until a fixed burnishing procedure is established, shall be burnished to the manufacturer's instructions in agreement with the technical service.

1.2. Tests and requirements

1.2.1. Conformance with Regulation No. 13

1.2.1.1. The braking system of the vehicle shall be tested according to the requirements for the vehicle category in question (M₃, N₂ or N₃) in Regulation No. 13, annex 4, paragraphs 1. and 2. The applicable requirements or tests are:

1.2.1.1.1. Service braking system

1.2.1.1.1.1. Type-0 test with engine disconnected, vehicle laden

1.2.1.1.1.2. Type-0 test with engine connected, vehicle unladen and laden, according to Regulation No. 13, annex 4, paragraphs 1.4.3.1. (stability test) and 1.4.3.2. (only the test with initial speed $v = 0.8 v_{\max}$).

1.2.1.1.1.3. Type-I test according to Regulation No. 13, annex 4, paragraphs 1.5.1. and 1.5.3.

1.2.1.1.1.4. Type-II test

The laden vehicle must be tested in such a manner that the energy input is equivalent to that recorded in the same period of time with the laden vehicle driven at an average speed of 30 km/h on a 2.5 per cent down-gradient for a distance of 6 km with the gear disengaged, the braking energy being taken by the service brakes alone.

1.2.1.1.2. Secondary braking system

1.2.1.1.2.1. Type-0 test with engine disconnected, vehicle laden (this test may be omitted if covered by tests according to paragraph 1.2.2. of this annex).

- 1.2.1.1.3. Parking braking system
(Only applicable if the brakes for which lining approval is sought are used for parking).
- 1.2.1.1.3.1. Downhill test at 18 per cent gradient, vehicle laden
- 1.2.1.2. The vehicle must satisfy all relevant requirements stated in Regulation No. 13, annex 4, paragraph 2. for that category of vehicle.
- 1.2.2. Additional requirements (split axle test)
- For the tests mentioned below the vehicle shall be fully laden and all brake applications made with engine disconnected, on a level road.
- The vehicle service brake control system shall be equipped with a means of isolating front and rear axle brakes so that either may be used independently of the other.
- Where brake lining assembly approval or drum brake lining approval is required for front axle brakes the rear axle brakes shall remain inoperative throughout the test.
- Where brake lining assembly approval or drum brake lining approval is required for rear axle brakes the front axle brakes shall remain inoperative throughout the test.
- 1.2.2.1. Cold performance equivalence test
- A comparison of the cold performance of the replacement brake lining assembly or the replacement drum brake lining and the original brake lining assembly or the original drum brake lining shall be made by comparing the results of testing to the following method.
- 1.2.2.1.1. Make a minimum of six brake applications at spaced increments of pedal force or line pressure up to wheel lock or, alternatively, up to a mean fully developed deceleration of 3.5 m/s^2 or up to the maximum allowed pedal force or up to the maximum line pressure from an initial speed of 45 km/h and with a brake temperature # 100EC at the start of each application.
- 1.2.2.1.2. Note and plot pedal force or line pressure and mean fully developed deceleration for each application, and determine the pedal force or line pressure required to achieve (if possible) a mean fully developed deceleration of 3 m/s^2 . If this value cannot be achieved determine alternatively the pedal force or line pressure required to achieve maximum deceleration.
- 1.2.2.1.3. The replacement brake lining assembly or the replacement drum brake lining shall be considered to show similar performance characteristics to the original brake lining assembly or the original drum brake lining if the achieved mean fully developed decelerations at the same control force or line pressure in the upper two thirds of the generated curve are

within 15 per cent of those obtained with the original brake lining assembly or the original drum brake lining.

1.2.2.2. Speed sensitivity test

1.2.2.2.1. Using the pedal force derived from paragraph 1.2.2.1.2. of this annex and with initial brake temperature # 100EC, make three brake applications from each of the following speeds:

40 km/h down to 20 km/h,
60 km/h down to 40 km/h and
80 km/h down to 60 km/h (if $v_{max} \geq 90$ km/h)

1.2.2.2.2. Average the results for each group of three applications and plot speed against corresponding mean fully developed deceleration.

1.2.2.2.3. Mean fully developed decelerations recorded for the higher speeds shall lie within 25 per cent of that recorded for the lowest speed.

2. Inertia dynamometer test

2.1. Test equipment

For the tests an inertia dynamometer shall be equipped with the vehicle brake in question. The dynamometer shall be instrumented for continuous recording of rotational speed, brake torque, pressure in the brake line, number of rotations after brake application, braking time and brake rotor temperature.

2.1.1. Test conditions

2.1.1.1. The rotational mass of the dynamometer shall correspond to half the axle portion of 0.55 of the maximum vehicle mass and the rolling radius of the largest tyre that is authorised for that vehicle type(s).

2.1.1.2. The initial dynamometer rotational speed shall correspond to the linear vehicle speed as stated in the paragraphs below and shall be based on the dynamic rolling radius of the smallest tyre that is authorized for that vehicle type(s).

2.1.1.3. Brake lining assemblies or drum brake linings submitted for the test shall be fitted to the brake and, until a fixed burnishing procedure is established, shall be burnished to the manufacturer's instructions in agreement with the technical service.

2.1.1.4. If cooling air is used, the speed of the airflow at the brake shall be:

$$v_{air} = 0.33v$$

where:

v = vehicle test speed at initiation of braking.

2.1.1.5. The actuation cylinder fitted to the brake must be of the smallest size that is authorized for that vehicle type(s).

2.2. Tests and requirements

2.2.1. Tests derived from ECE Regulation No. 13

2.2.1.1. Type-0 test

From the initial speed of 60 km/h with a brake temperature # 100EC at the start of each application make a minimum of six brake applications at spaced intervals of line pressure up to the line pressure that is permanently guaranteed by the braking system of the vehicle type(s) (e.g. cut in pressure of the compressor). A mean fully developed deceleration of at least 5 m/s^2 must be achieved.

2.2.1.2 Type-0 test, high speed performance

Make three brake applications with a brake temperature of # 100EC at the start of each application from a speed of 100 km/h where approval is directed to vehicles of category N_2 and 90 km/h where approval is directed to vehicles of categories M_3 and N_3 using the guaranteed line pressure as defined in paragraph 2.2.1.1. The mean value of the achieved mean fully developed decelerations of the three applications must be at least 4 m/s^2 .

2.2.1.3 Type-I test

2.2.1.3.1. Heating procedure

Make 20 consecutive snub applications with $v_1 = 60 \text{ km/h}$ and $v_2 = 30 \text{ km/h}$ with a cycle time of 60 s starting at a brake temperature of # 100EC at the first application. The line pressure shall correspond to a deceleration of 3 m/s^2 at the first application and must remain constant throughout the succeeding applications.

2.2.1.3.2. Hot performance

On completion of the heating procedure the hot performance shall be measured under the conditions of paragraph 2.2.1.1. above using the guaranteed line pressure as defined in paragraph 2.2.1.1. (the temperature conditions may be different). The mean fully developed deceleration with the heated brake must not be less than 60 per cent of the value achieved with the cold brake or 4 m/s^2 .

2.2.1.3.3. Recovery

Starting 120 s after the hot performance brake application make 5 full stops with the line pressure used in paragraph 2.2.1.3.1. above and with intervals of at least 2 minutes from the initial speed of 60 km/h. At the beginning of the fifth application the brake temperature shall be # 100EC and the mean fully developed deceleration achieved shall be within 10 per cent of that calculated from the

relation line pressure/deceleration of the Type-0 test at 60 km/h.

2.2.1.4 Type-II test

2.2.1.4.1. Heating procedure

The brakes shall be heated by constant braking torque corresponding to a deceleration of 0.15 m/s^2 at a constant speed of 30 km/h during a period of 12 minutes.

2.2.1.4.2. Hot performance

On completion of the heating procedure the hot performance shall be measured under the conditions of paragraph 2.2.1.1. above using the guaranteed line pressure as defined in paragraph 2.2.1.1. (the temperature conditions may be different). The mean fully developed deceleration with the heated brake must not be less than 3.75 m/s^2 .

2.2.1.5. Static test for parking performance

2.2.1.5.1. For the whole range of applications determine the worst case regarding input force to the brake, maximum vehicle mass to be braked by one axle, and tyre radius.

2.2.1.5.2. Apply the brake with the input force as determined under paragraph 2.2.1.5.1. above.

2.2.1.5.3. Put a slowly increasing torque on the dyno shaft in order to turn the drum or disc. Measure the output torque at the brake in the moment the dyno shaft begins to move and calculate corresponding axle braking force using the tyre radius as determined under paragraph 2.2.1.5.1.

2.2.1.5.4. The brake force measured under paragraph 2.2.1.5.3. divided by one-half of the vehicle mass as determined under paragraph 2.2.1.5.1. must give at least a quotient of 0.18.

2.2.2. Cold performance equivalence test

A comparison of the cold performance of the replacement brake lining assembly or the replacement drum brake lining and the original brake lining assembly or the original drum brake lining shall be made by comparing the results of the Type-0 test as described in paragraph 2.2.1.1.

2.2.2.1. The Type-0 test as prescribed in paragraph 2.2.1.1. shall be performed with one set of the original brake lining assembly or the original drum brake lining.

2.2.2.2. The replacement brake lining assembly or the replacement drum brake lining shall be considered to show similar performance characteristics to the original brake lining assembly or the original drum brake lining if the achieved mean fully developed decelerations at the same line pressure in the upper two thirds of the generated curve are within 15 per cent of

those obtained with the original brake lining assembly or the original drum brake lining.

2.2.3. Speed sensitivity test

2.2.3.1. Using the guaranteed line pressure as defined in paragraph 2.2.1.1. and with initial brake temperature # 100EC, make three brake applications from each of the following speeds:

60 km/h down to 30 km/h,
80 km/h down to 60 km/h, and
110 km/h down to 80 km/h (if v_{\max} \geq 90 km/h).

2.2.3.2. Average the results for each group of three applications and plot speed against corresponding mean fully developed deceleration.

2.2.2.3. Mean fully developed decelerations recorded for the higher speeds shall lie within 25 per cent of that recorded for the lowest speed.

Annex 5

REQUIREMENTS FOR REPLACEMENT BRAKE LINING ASSEMBLIES FOR VEHICLES OF CATEGORIES O₁ AND O₂

1. General

The test method described in this annex is based on an inertia dynamometer test. Alternatively the tests may be carried out on a test vehicle or on a rolling road test bench provided that the same test conditions are achieved and the same parameters measured as in the inertia dynamometer test.

2. Test equipment

For the tests an inertia dynamometer shall be equipped with the vehicle brake in question. The dynamometer shall be instrumented for continuous recording of rotational speed, brake torque, pressure in the brake line or actuation force, number of rotations after brake application, braking time and brake rotor temperature.

2.1. Test conditions

2.1.1. The rotational mass of the dynamometer shall correspond to half the relevant axle portion of the maximum vehicle mass and the rolling radius of the largest tyre that is authorized for that vehicle type(s).

2.1.2. The initial dynamometer rotational speed shall correspond to the linear vehicle speed as stated in paragraph 3.1. of this annex and shall be based on the dynamic rolling radius of the smallest tyre that is authorized for that vehicle type(s).

2.1.3. Brake linings submitted for the test shall be fitted to the relevant brake and, until a fixed burnishing procedure is established, shall be burnished to the manufacturer's instructions in agreement with the technical service.

2.1.4. If cooling air is used, the speed of the airflow at the brake shall be:

$$v_{\text{air}} = 0.33v$$

where:

v = vehicle test speed at initiation of braking.

2.1.5. The actuation device fitted to the brake must correspond to the vehicle installation.

3. Tests and requirements

3.1. Type-0 test

From the initial speed of 60 km/h with a brake temperature # 100EC at the start of each application make a minimum of six consecutive brake applications at spaced intervals of line pressure or application force up to the maximum line pressure or up to 6 m/s² deceleration. Repeat the last brake application using an initial speed of 40 km/h.

3.2. Type-I test

3.2.1. Heating procedure

The brake shall be heated with continuous braking according to the requirement of Regulation No. 13, annex 4, paragraph 1.5.2. starting with a brake rotor temperature # 100EC.

3.2.2. Hot performance

On completion of the heating procedure the hot performance from an initial speed of 40 km/h shall be measured under the conditions of paragraph 3.2.1. above using the same line pressure or application force (the temperature conditions may be different). The mean fully developed deceleration with the heated brake must not be less than 60 per cent of the value achieved with the cold brake or 3.5 m/s².

3.3. Cold performance equivalence test

A comparison of the cold performance of the replacement brake lining assembly and the original brake lining assembly shall be made by comparing the results of the Type-0 test as described in paragraph 3.1.

3.3.1. The Type-0 test as prescribed in paragraph 3.1. shall be performed with one set of the original brake lining assembly.

3.3.2. The replacement brake lining assembly shall be considered to show similar performance characteristics to the original brake lining assembly if the achieved mean fully developed decelerations at the same line pressure or application force in the upper two thirds of the generated curve are within 15 per cent of those obtained with the original brake lining assembly.

Annex 6

REQUIREMENTS FOR REPLACEMENT BRAKE LINING ASSEMBLIES AND DRUM BRAKE LININGS
FOR VEHICLES OF CATEGORIES O₃ AND O₄

1. Test conditions

The tests prescribed in this annex may be carried out alternatively on a test vehicle or on an inertia dynamometer or on a rolling road test bench under the same conditions as mentioned in Regulation 13, annex 11, appendix 2, paragraphs 3.1. to 3.4.

Brake linings submitted for test shall be fitted to the relevant brakes and, until a fixed burnishing procedure is established, shall be burnished to the manufacturer's instructions in agreement with the technical service.

2. Tests and requirements

2.1. Conformance with Regulation No. 13, annex 11

The brakes shall be tested according to the requirements of Regulation No. 13, annex 11, appendix 2, paragraph 3.5.

2.1.1. The results shall be reported in a form according to Regulation No. 13, annex 11, appendix 3.

2.1.2. A comparison shall be made between these results and those obtained with the original brake lining assemblies or the original drum brake linings under the same conditions.

2.1.3. The achieved hot performance at the same input torque of the replacement brake lining assembly or the replacement drum brake lining in the Type-I test or in the Type-III test (whichever is applicable) must be:

- (a) equal to or higher than the hot performance of the original brake lining assembly or the original drum brake lining, or
- (b) at least 90 per cent of the cold performance of the replacement brake lining assembly or the replacement drum brake lining.

The corresponding stroke of the actuator must not be \leq 110 per cent of the value achieved with the original brake lining assembly or the original drum brake lining and must not exceed the value s_p as defined in annex 11, appendix 2, paragraph 2. of Regulation No. 13. In the case where the original brake lining assembly or drum brake lining has been tested against the Type-II test requirements, the minimum requirements of Regulation No. 13, annex 4, paragraph 1.7.2. (Type-III test) are applicable for the replacement brake lining assembly or drum brake lining.

2.2. Cold performance equivalence test (Type-0)

2.2.1. Under the conditions of paragraph 1 of this annex and from an initial speed of 60 km/h with a brake temperature \leq 100°C make 6 brake

applications at spaced intervals of control force or line pressure up to 6.5 bar or an achieved deceleration of 6 m/s².

- 2.2.2. Note and plot control force or line pressure and mean brake torque or mean fully developed deceleration for each application.
 - 2.2.3. Compare the results with those obtained with the original brake lining assemblies or the original drum brake linings under the same test conditions.
 - 2.2.4. The replacement brake lining assembly or the replacement drum brake lining shall be considered to show similar performance characteristics to the original brake lining assembly or the original drum brake lining if the achieved mean fully developed decelerations at the same input force or line pressure in the upper two thirds of the generated curve are within -5 per cent and +15 per cent of those obtained with the original brake lining assembly or the original drum brake lining.
-

Annex 7

REQUIREMENTS FOR REPLACEMENT BRAKE LINING ASSEMBLIES
FOR VEHICLES OF CATEGORY L

1. Test conditions

- 1.1. A vehicle which is representative of the type(s) for which the replacement brake lining assembly approval is required shall be equipped with the brake lining assemblies of the type for which approval is requested and instrumented for brake testing as required by Regulation No. 78.
- 1.2. Brake lining assemblies submitted for the test shall be fitted to the relevant brakes and, until a fixed burnishing procedure is established, shall be burnished to the manufacturer`s instructions in agreement with the technical service.
- 1.3. In the case of brake lining assemblies for vehicles with a combined braking system in the meaning of paragraph 2.9. of Regulation No. 78 the combination(s) of brake lining assemblies for the front and the rear axle to which the approval shall be directed must be tested.

The combination may consist of replacement brake lining assemblies for both axles and/or a replacement brake lining assembly on one and an original brake lining assembly on the other axle.

2. Tests and requirements

- 2.1. Conformance with Regulation No. 78
- 2.1.1. The braking system of the vehicle shall be tested according to the requirements for the vehicle category in question (L₁, L₂, L₃, L₄ or L₅) in Regulation No. 78, annex 3, paragraph 1. The applicable requirements or tests are:
- 2.1.1.1. Type-0 test with engine disconnected
- The test is to be carried out only in the laden condition. Make a minimum of six brake applications at spaced increments of control force or line pressure up to wheel lock, or up to a deceleration of 6 m/s² or up to the maximum allowed control force.
- 2.1.1.2. Type-0 test with engine connected
- Only applicable for vehicles of categories L₃, L₄ and L₅.
- 2.1.1.3. Type-0 test with wet brakes
- Not applicable to vehicles of category L₅ or in cases of drum brakes or fully enclosed disc brakes not subjected to this test during approval to Regulation No. 78.
- 2.1.1.4. Type-I test
- Only applicable for vehicles of categories L₃, L₄ and L₅.

2.1.2. The vehicle must satisfy all the relevant requirements stated in Regulation No. 78, annex 3, paragraph 2 for that category of vehicles.

2.2. Additional requirements

2.2.1. Cold performance equivalence test

A comparison of the cold performance of the replacement brake lining assembly and the original brake lining assembly shall be made by comparing the results of the Type-0 test as described in paragraph 2.1.1.1.

2.2.1.1. The Type-0 test as prescribed in paragraph 2.1.1.1. shall be performed with one set of the original brake lining assembly.

2.2.1.2. The replacement brake lining assembly shall be considered to show similar performance characteristics to the original brake lining assembly if the achieved mean fully developed decelerations at the same line pressure in the upper two thirds of the generated curve are within 15 per cent of those obtained with the original brake lining assembly.

2.2.2. Speed sensitivity test

This test is only applicable for vehicles of categories L₃, L₄ and L₅ and shall be carried out with the laden vehicle under the conditions of the Type-0 test with engine disconnected. However, the test speeds are different.

2.2.2.1. From the results of the Type-0 test as described in paragraph 2.1.1.1. determine the control force or line pressure corresponding to the minimum required mean fully developed deceleration for that category of vehicle.

2.2.2.2. Using the control force or line pressure determined in paragraph 2.2.2.1. and with initial brake temperature # 100EC, make three brake applications from each of the following speeds:

40 km/h, 80 km/h and 120 km/h (if v_{max} \geq 130 km/h)

2.2.2.3. Average the results for each group of three applications and plot speed against corresponding mean fully developed deceleration.

2.2.2.4. Mean fully developed decelerations recorded for the higher speeds shall lie within 15 per cent of that recorded for the lowest speed.

Annex 8

DETERMINATION OF FRICTION BEHAVIOUR BY MACHINE TESTING

1. INTRODUCTION
 - 1.1. Samples of a replacement brake lining assembly type shall be tested on a machine capable of generating the test conditions and applying the test procedures described in this annex.
 - 1.2. Test results shall be evaluated to determine sample friction behaviour.
 - 1.3. The friction behaviour of samples shall be compared to assess conformity with the standard registered for a replacement brake lining assembly type.
2. Replacement brake lining assemblies for vehicles of categories M₁, M₂, N₁, Q₁, Q₂, and L
 - 2.1. Equipment
 - 2.1.1. The machine shall be designed to accept and operate a full size brake similar to those fitted to the vehicle axle used for approval testing to paragraph 5. of this Regulation.
 - 2.1.2. The disc or drum rotational speed shall be 660 ± 10 1/min 1/ without load and shall not fall below 600 1/min on full load.
 - 2.1.3. The test cycles and brake applications during the cycles to be adjustable and automatic.
 - 2.1.4. Output torque or brake pressure (constant torque method) and working surface temperature shall be recorded.
 - 2.1.5. Provisions shall be made to direct cooling air across the brake at a rate of 600 ± 60 m³/h.
 - 2.2. Test procedure
 - 2.2.1. Sample preparation

The manufacturer's bedding schedule shall ensure a minimum of 80 per cent surface contact area for pad assemblies without exceeding a surface temperature of 300°C and 70 per cent surface contact area for the leading shoe assemblies without exceeding a surface temperature of 200°C.
 - 2.2.2. Test schedule

The test schedule comprises a number of consecutive braking cycles each containing X braking intervals of 5 seconds brake applied followed by 10 seconds brake released.

1/ In the case of vehicles of categories L₁ and L₂, a lower test speed may be used.

The following two methods may be used alternatively:

2.2.2.1. Test schedule with constant pressure

2.2.2.1.1. Pad assemblies

The hydraulic pressure p under the piston(s) of the calliper shall be constant following the formula:

$$p = \frac{M_d}{0.57 \cdot r_w \cdot A_k}$$

$M_d = 150 \text{ Nm}$ for $A_k \leq 18.1 \text{ cm}^2$

$M_d = 300 \text{ Nm}$ for $A_k > 18.1 \text{ cm}^2$

$A_k =$ area of calliper piston(s)

$r_w =$ effective radius of disc

No of cycle	Number of brake applications X	Initial brake rotor temperature (EC)	Max. brake rotor temperature (EC)	Forced cooling
1	1 x 10	# 60	open	no
2-6	5 x 10	100	open (350) <u>2/</u>	no
7	1 x 10	100	open	yes

2.2.2.1.2. Shoe assemblies

The mean contact pressure at the brake lining working surface shall be constant at $22 \pm 6 \text{ N/cm}^2$ calculated for a static brake without self-energizing.

No of cycle	Number of brake applications X	Initial brake rotor temperature (EC)	Max. brake rotor temperature (EC)	Forced cooling
1	1 x 10	# 60	200	yes
2	1 x 10	100	open	no
3	1 x 10	100	200	yes
4	1 x 10	100	open	no

2/ In the case of vehicles of category L, the temperature shall be limited to 350EC. If necessary, the number of applications per cycle must be reduced accordingly. However, in this case, the number of cycles shall be increased to keep the total number of applications constant.

2.2.2.2. Test schedule with constant torque

This method applies only for pad assemblies. The brake torque shall be constant within a tolerance of ± 5 per cent and adjusted to guarantee the maximum brake rotor temperatures given in the table below.

No of cycle	Number of brake applications X	Initial brake rotor temperature (EC)	Max. brake rotor temperature (EC)	Forced cooling
1	1 x 5	# 60	300-350 (200-250) <u>3</u> /	no
2-4	3 x 5	100	300-350 (200-250)	no
5	1 x 10	100	500-600 (300-350)	no
6-9	4 x 5	100	300-350 (200-250)	no
10	1 x 10	100	500-600 (300-350)	no
11-13	3 x 5	100	300-350 (200-250)	no
14	1 x 5	# 60	300-350 (200-250)	no

2.3. Evaluation of test results

Friction behaviour is determined from the brake torque noted at selected points in a test schedule. Where brake factor is constant, e.g. a disc brake, brake torque may be translated to coefficient of friction.

2.3.1. Pad assemblies

2.3.1.1. The operational coefficient of friction (F_{op}) is the mean of the values recorded during cycles two to seven (constant pressure method) or during cycles 2-4, 6-9 and 11-13 (constant torque method); measurement being made one second after commencing the first brake application of each cycle.

2.3.1.2. The maximum coefficient of friction (F_{max}) is the highest value recorded during all cycles.

2.3.1.3. The minimum coefficient of friction (F_{min}) is the lowest value recorded during all cycles.

2.3.2. Shoe assemblies

2.3.2.1. The mean torque (M_{mean}) is the average of the maximum and minimum values of brake torque recorded during the fifth brake application of cycles one and three.

2.3.2.2. The hot torque (M_{hot}) is the minimum brake torque developed during cycles two and four. If the temperature exceeds 300EC during these cycles the value at 300EC is to be taken as M_{hot} .

3/ Values in brackets for vehicles of category L.

- 2.4. Acceptance criteria
- 2.4.1. With each application for approval of a brake lining assembly type there shall be submitted:
- 2.4.1.1. for pad assemblies, values for F_{op} , F_{min} , F_{max} .
- 2.4.1.2. for shoe assemblies, values for M_{mean} and M_{hot} .
- 2.4.2. During production of an approved brake lining assembly type, test samples must demonstrate compliance with the values registered under paragraph 2.4.1. of this annex with the following tolerances:
- 2.4.2.1. for disc brake pads:
- F_{op} \pm 15 per cent of registered value
 F_{min} \$ registered value
 F_{max} # registered value
- 2.4.2.2. for simplex drum brake linings:
- M_{mean} \pm 20 per cent of registered value
 M_{hot} \$ registered value.
3. Brake lining assemblies and drum brake linings for vehicles of categories M_3 , N_2 , N_3 , O_3 , and O_4
- 3.1. Equipment
- 3.1.1. The machine shall be equipped with a disc brake of the fixed calliper type with a cylinder diameter of 60 mm and a solid (not ventilated) disc having a diameter of 278 ± 2 mm and a thickness of $12 \text{ mm} \pm 0.5 \text{ mm}$. A rectangular piece of the friction material with an area of $44 \text{ cm}^2 \pm 0.5 \text{ cm}^2$ and a thickness of at least 6 mm shall be attached to the backing plate.
- 3.1.2. The disc rotational speed shall be 660 ± 10 1/min without load and shall not fall below 600 1/min on full load.
- 3.1.3. The mean contact pressure at the brake lining working surface shall be constant at $75 \text{ N/cm}^2 \pm 10 \text{ N/cm}^2$.
- 3.1.4. The test cycles and brake applications during the cycles to be adjustable and automatic.
- 3.1.5. Output torque and working surface temperature shall be recorded.
- 3.1.6. Provisions shall be made to direct cooling air across the brake at a rate of $600 \pm 60 \text{ m}^3/\text{h}$.
- 3.2. Test procedure
- 3.2.1. Sample preparation
- The manufacturer's bedding procedure shall ensure a minimum of 80 per cent surface contact area without exceeding a surface temperature of 200EC.

3.2.2. Test schedule

The test procedure comprises a number of consecutive braking cycles each containing a number of X braking intervals of 5 seconds brake applied followed by 10 seconds brake released.

No of cycle	Number of brake applications X	Initial brake rotor temperature (EC)	Forced cooling
1	5	100	yes
2	5	increasing # 200	no
3	5	200	no
4	5	increasing # 300	no
5	5	300	no
6	3	250	yes
7	3	200	yes
8	3	150	yes
9	10	100	yes
10	5	increasing # 300	no
11	5	300	no

3.3. Evaluation of test results

Friction behaviour is determined from the brake torque noted in selected cycles of the test schedule. Brake torque shall be translated to coefficient of friction F.

The F-value of each brake application shall be determined as the mean value of the 5 seconds brake applied.

3.3.1. The operational coefficient of friction F_{op1} is the mean value of F recorded for the brake applications in cycles 1 and F_{op2} is the mean value of F recorded for the brake applications in cycle 9.

3.3.2. The maximum coefficient of friction F_{max} is the highest value of F recorded in an application during cycles 1 to 11 inclusive.

3.3.3. The minimum coefficient of friction F_{min} is the lowest value of F recorded in an application during cycles 1 to 11 inclusive.

3.4. Acceptance criteria

3.4.1. With each application for approval of a replacement brake lining assembly type or a replacement drum brake lining type, there shall be submitted values for F_{op1} , F_{op2} , F_{min} and F_{max} .

3.4.2. During production of an approved replacement brake lining assembly type or replacement drum brake lining type, test samples must demonstrate compliance with the values registered under paragraph 3.4.1. of this annex within the following tolerances:

F_{op1} , $F_{op2} \pm 15$ per cent of the registered value
 F_{min} \$ registered value
 F_{max} # registered value.